



FARMNAVIGATOR
Automatic Steering

FARMNAVIGATOR Automatic Steering: options



FARMNAVIGATOR
Auto-Steering *Kit*

MDU-G4
K10ASSKY01



FARMNAVIGATOR
Auto-Steering *Kit*

MDU-G5
K10ASS0Y03



FARMNAVIGATOR
Auto-Steering

ECU-S1
KAASS00001

For steer-ready vehicles

Automatic Steering: with G7 series

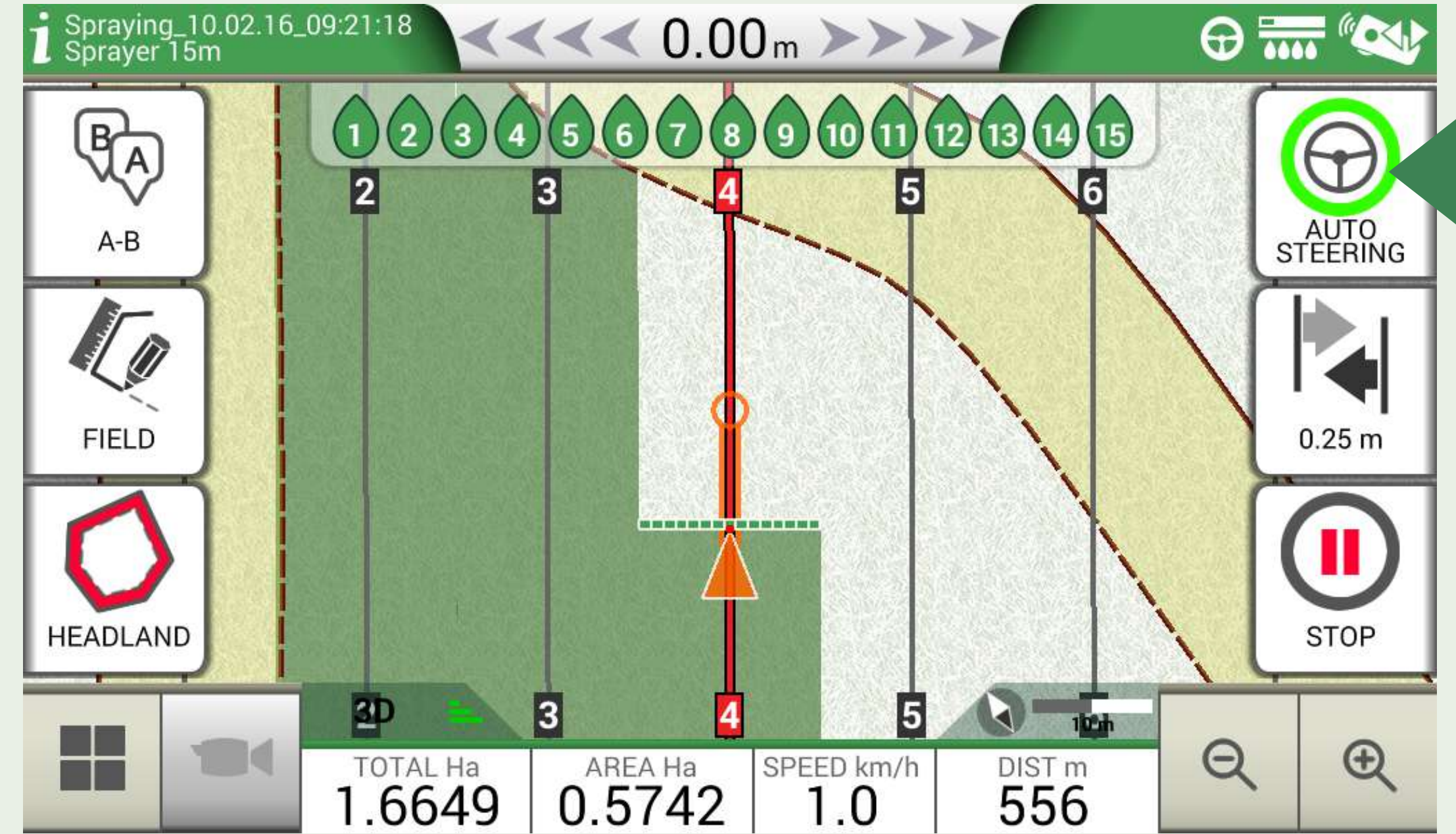
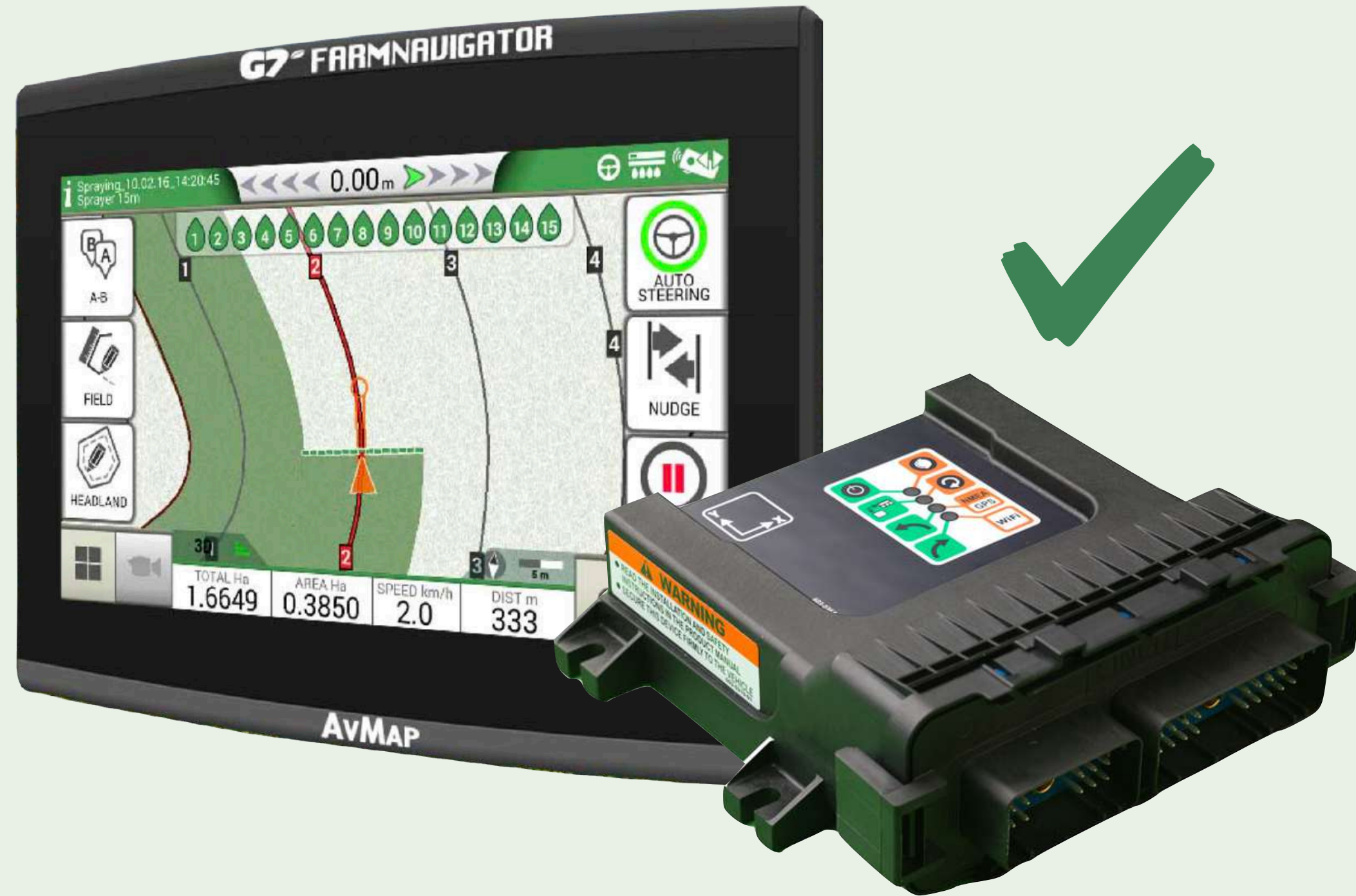

Automatic Setup and calibration

Easily configure the ECU by following the wizard on the G7 Plus / G7 Iso display.

Easy to use

Activate the Auto-Steering by tapping the icon on the G7 Plus / G7 Iso display.



FARMNAVIGATOR Auto-Steering^{Kit}

MDU-G4

K10ASSKY01

Mounts on any existing steering wheel

- ✓ Patented universal ring
- ✓ Easy to move from one vehicle to another
- ✓ High torque gear
- ✓ Quiet and very fast, it can steer in any type of terrain
- ✓ It also works in reverse

Automatic Steering: MDU-G5



Auto-Steering^{Kit}

MDU-G5

K10ASS0Y03

- ✓ Custom installation with dedicated kit
- ✓ Permanent installation for maximum safety
- ✓ High torque gear

FARMNAVIGATOR Automatic Steering: ECU-S1



FARMNAVIGATOR
Auto-Steering *Kit*

ECU-S1
KAASS00001

For steer-ready vehicles

Some examples of steer-ready vehicles:

- ▶ DF TTV (agrosky)
- ▶ Kubota M7
- ▶ CNH, Puma, Magnum, Optum, STX
- ▶ NH, T7, T8
- ▶ Valtra
- ▶ Massey Ferguson
- ▶ Challenger
- ▶ Fendt



Automatic Steering: comparison



MDU-G4



MDU-G5



ECU

Installation	On any vehicle (Except Claas)	Only with correct Kit	Steer-ready vehicles
Possibility to be moved on other vehicles	✓	✗	✗
Precision	Maximum	Maximum	Maximum
Input speed	Good	High	High
Safety	Maximum	High	Maximum
Speed of work	1,6km/h standard 0,6km/h optional	1,0km/h standard 0,1km/h optional	0,6km/h standard
Angular sensor	✗	✗	Standard
Cost	€€	€€€	€€ (But the vehicle has to be ready)

Automatic Steering: Installation MDU-G4



Automatic Steering: compatibility MDU-G4

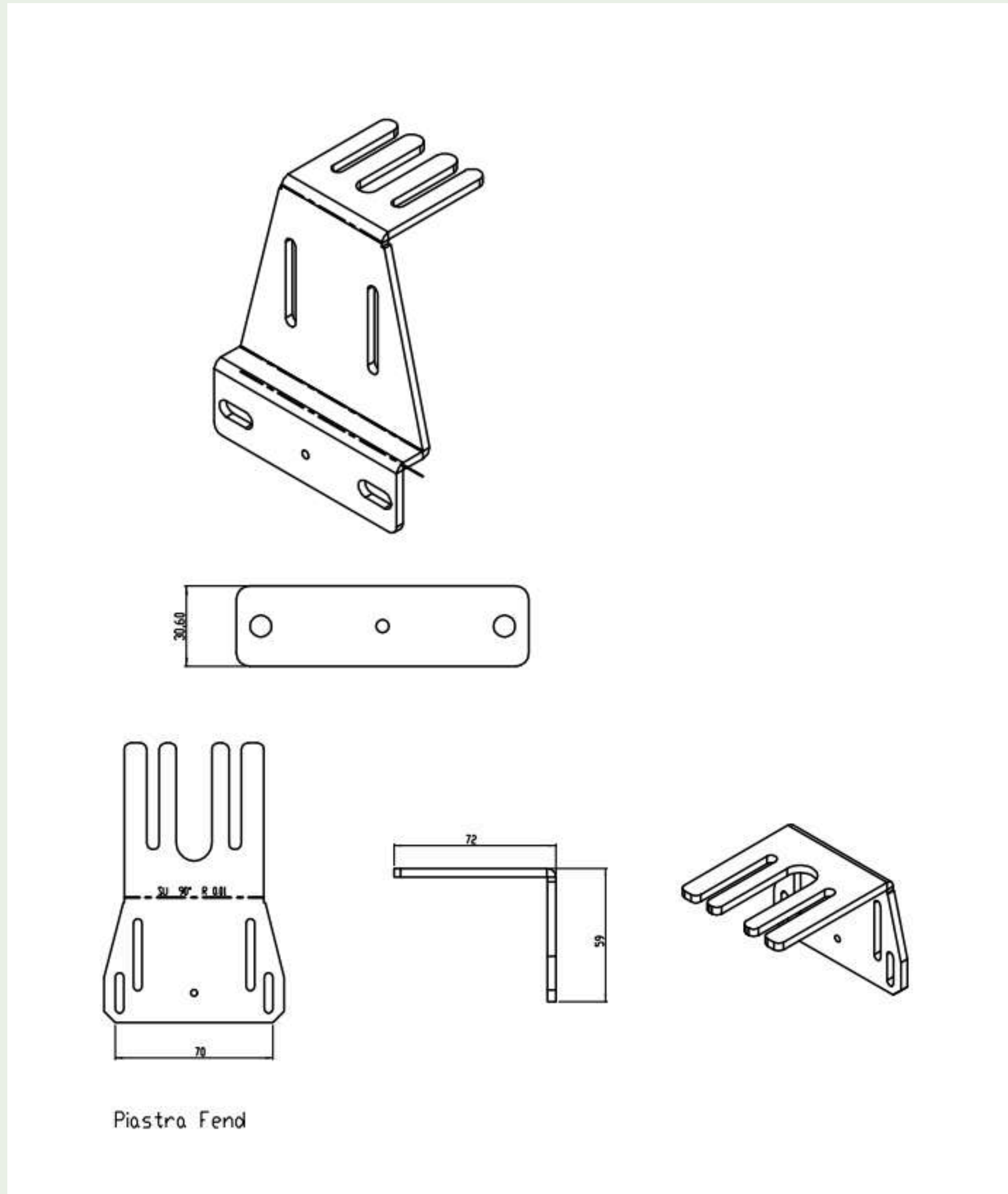

Part description	Product Code (for orders)
CASE/NH Puma T6 T7 T8	KAAARKC001
MDU-G4 Bracket A	K10MDU001A
MDU-G4 Bracket B	K10MDU002A
<p>Case NH:</p> <p>(Some changes to the kit may be required during installation)</p> <p><i>ATTENTION: This kit is included, by default, in the MDU-G4 kit!</i></p>	<ul style="list-style-type: none"> -Maxxum, 110, 115, 120, 125, 130, 140 -Maxxum MX, 100, 110, 120, 135, 150, 170 -Maxxum Pro, 110, 120, 125, 130, 140 -Maxxum X Line, 100, 110, 115, 125, 140 -MX Maxxum, 110, 115, 120, 125, 130, 140 -MXU Pro, 100, 110, 115, 125, 135, X Line -MXU, 100, 110, 115, 125, 130, 135 -Puma, 115, 125, 140, 155, 165, 180, 195, 210 -New Holland: TS-A, TS-A Plus, TS-A Delta, -New Holland: T6., T60x0, T7., T70x0, T75x0
<p>Bracket A:</p> <p>(Some changes to the kit may be required during installation)</p>	<ul style="list-style-type: none"> - John Deere 6xx0, 7xx0, 6xxxM, - CASE Magnum 7xx0, 8xx0 - NH TG - NH TS, TS-A - Case PUMA, MXU, Maxxum
<p>Bracket B:</p> <p>(Some changes to the kit may be required during installation)</p>	<ul style="list-style-type: none"> - Fendt Vario models: 711, 712, 714, 716, 815, 817, 818, 916, 920, 924, 926, 930, 933 - Fendt Favorit modelli: 711, 712, 714, 716, 816, 818, 822, 824, 916, 920, 924, 926 - All other Fendt models

Automatic Steering: Installation MDU-G5



Automatic Steering: compatibility MDU-G5

Part description	Product code (for orders)
CNH / Agco	KAASS00004
JD 6000/7000 NON Premium	KAASS00005
CASE/NH	KAASS00006
CASE MXM TL/TM	KAASS00011
<p>The kit includes the parts for the correct installation of the MDU-G5 engine on the specific tractor. Make sure the required model is in the list. Otherwise, the installation cannot be performed correctly</p>	
CNH/Agco KAASS00004:	<ul style="list-style-type: none"> -Case Magnum -Case Steiger -Case Quadtrac -Case STX -Challenger (MT4 ABCD, MT5 ABCD, MT6 ABCD) -MF (from 54xx to 8690) -McCormik (MC, MTX, TTX, ZTX) -New Holland (T8, T80x0, TGx)
JD 6000/7000 NON Premium KAASS00005:	<ul style="list-style-type: none"> -JD 61x0, 62x0, 63x0, 64x0, 65x0, 66x0, 68x0, 69x0 -JD 71x0, 72x0, 73x0, 74x0, 75x0, 76x0, 77x0, 78x0, 79x0 -JD 81x0, 82x0, 83x0, 84x0, 8520, 8530 -JD 91x0, 92x0, 93x0, 94x0, 95x0, 96x0 -JD 6xx0M, 6xx5M -JD 82xxR, 83xxR - CLAAS ELIOS
CASE/NH KAASS00006:	<ul style="list-style-type: none"> -Case Maxxum -Case MXU -Case Puma -New Holland T50x0 -New Holland T6.x -New Holland T60x0 Elite -New Holland T7.x -New Holland T70x0 -New Holland TSx
CASE MXM TL/TM KAASS00011:	<ul style="list-style-type: none"> -Case MXM (120 - 190) -New Holland TM -New Holland TL -Case JXU

Automatic Steering: Installation ECU-S1

